

Chip formation through cutter positioning

Milling is a cyclic process with the cutting edge entering and exiting the workpiece. The thickness of the chip being generated is constantly changing when feeding the cutter in a radial direction (feeding axially/plunging has a constant chip thickness).

The effect of the cycle on the cutting edge is divided into three clear cutting zones which are determined by the position and feed direction of the cutter.

- 1) Entrance into cut
- 2) Arc of engagement in cut
- 3) Exit from cut

 Conventional/up milling

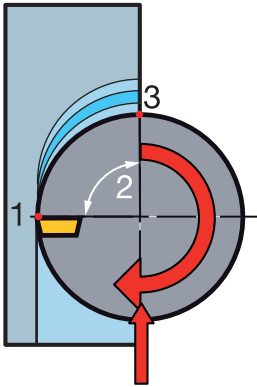

 Climb/down milling

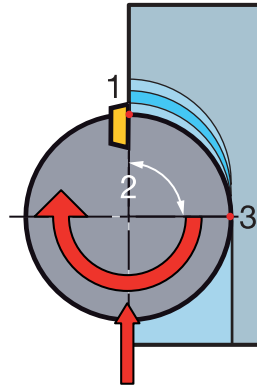

 Climb milling - zero chip thickness on exit

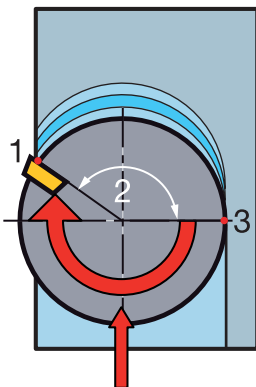

 Milling cutter in component centre

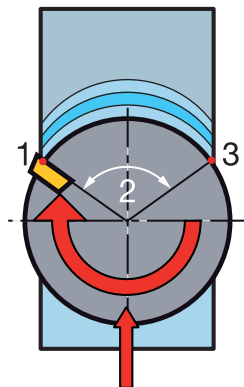

1) Entrance into cut

This is the least sensitive of the three cutting zones. Carbide copes well with the compressive stresses on impact of entering with a thicker chip.

- Climb/down milling is always recommended.
- Optimised entering angles to allow high feed rates with softest entry are:

$$\rightarrow a_e > 70\% D_c - \phi 30^\circ$$

$$\rightarrow a_e < 25\% D_c + \phi 30^\circ$$

$$a_e > 70\% D_c - \phi 30^\circ$$

$$a_e < 25\% D_c + \phi 30^\circ$$

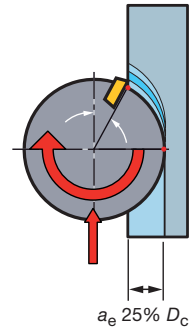
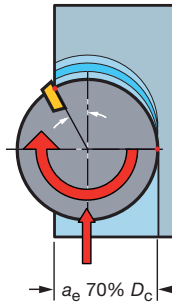

2) Arc of engagement in cut

The maximum arc of engagement possible is 180° when slotting, for finish profile milling the arc can be very small.

The higher the arc of engagement the greater the heat transferred into the cutting edge. Therefore the grade requirements are quite different depending upon the percentage radial immersion – a_e/D_c .

- High arc of engagement – CVD coated grades provide the best heat barrier.
- Low arc of engagement – here the chip thickness is normally lower and the sharper edge on PVD coated grades generate less heat and cutting pressure.

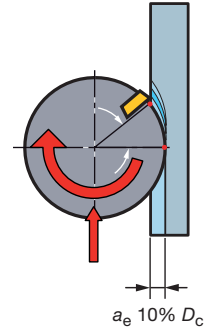
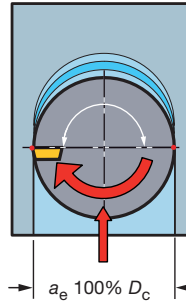

3) Exit from cut

Exiting from the workpiece with a thick chip can cause a drastic reduction in tool life when using carbide. The chip being formed lacks support at the final point of cut. It will try to bend rather than be cut and as it changes direction, the force applied (compressive to tensile) on the carbide geometry fractures the last point of the edge to leave.

- Always climb mill.
- Position cutter off centre leaving smallest chip thickness on exit.
- Program around interruptions in the workpiece (if this is not possible reduce feed rate).

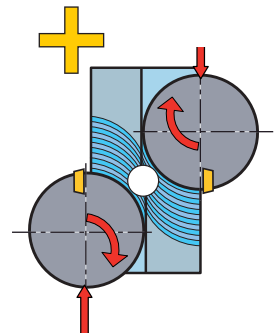
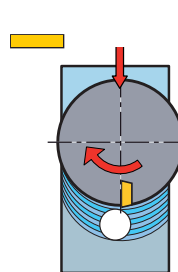
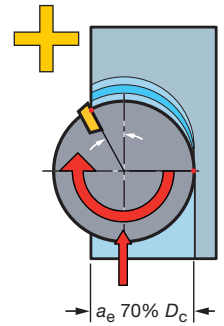
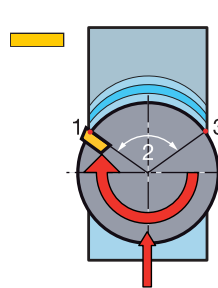

Programming methods

Entering the component

Thick chips on exit from cut will reduce tool life and can cause catastrophic failure.

It can be seen that when the cutter is programmed to enter straight into the work-piece, thick exit chips will be produced until the cutter is fully engaged into the work-piece.

The result of this is that the tool life will be dramatically reduced to a point that to achieve acceptable tool life the feed for the whole process tends to be reduced.

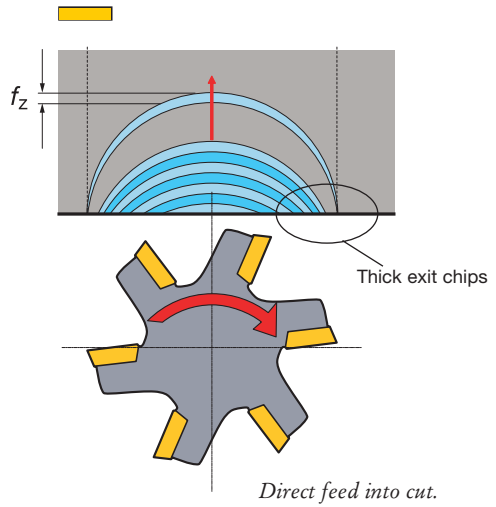

There are two solutions to remedy this common problem allowing optimised feed rate for when the cutter is fully engaged

- 1) Program straight into cut but with the feed reduced to 50% until the cutter is fully engaged.
- 2) Roll into cut in a clockwise motion (anti clockwise will not solve the thick chip thickness problem).

It can be seen that by rolling into cut the chip thickness on exit is always zero allowing higher feed and longer tool life.

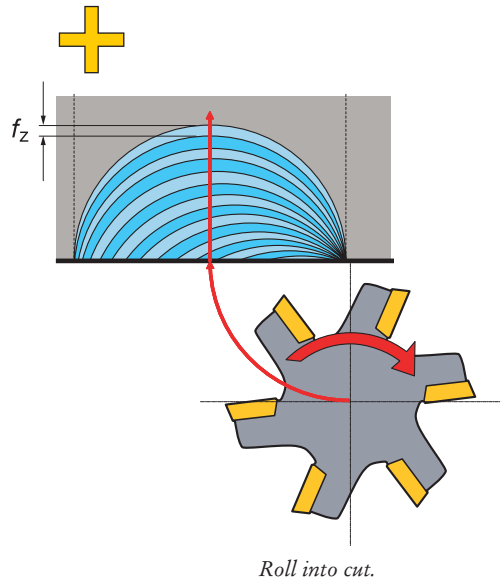

Effect of entry into cut on tool life

Roll on
technique

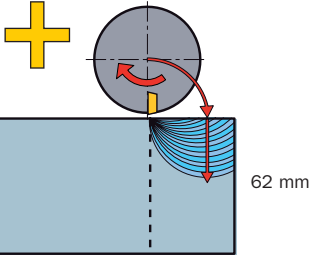

Full feed directly
into workpiece

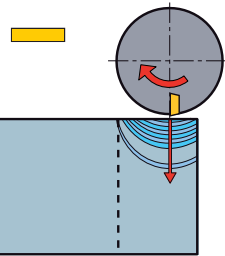

Material: Uddeholm Dievar (CMC 03.11)
Cutter: R390-032C5-11M095
Insert: R390-11T308M-PM 1030
Cutting data: v_c 200 m/min, f_z 0.2 mm/tooth, a_e 21.5 mm, a_p 3 mm



336 passes



84 passes



Material: Martensitic stainless steel – X22CrMoV12-1 (CMC 05.11)
Cutter: R300-052C5-12H
Insert: R300-1240E-PL 1030
Cutting data: v_c 300 m/min, f_z 0.35 mm/tooth, a_e 35 mm, a_p 3 mm

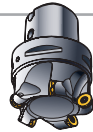

800 passes

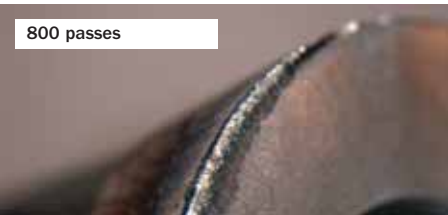

390 passes



Material: Heat resistant super alloy – Inconel 718 (46 HRC)
Cutter: R300-052C5-12H
Insert: R300-1240E-PL 1030
Cutting data: v_c 30 m/min, f_z 0.3 mm/tooth, a_e 35 mm, a_p 2 mm



15 passes

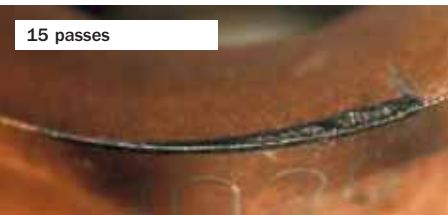

2 passes



Path in cut

Rolling around external corners

As described previously, entering the component directly will not provide an optimised process with reduced feed capability and short tool life.

It can also be seen in the illustrations below that sharp changes of direction in cut will provide the same result as the initial entry – therefore magnifying the problem.

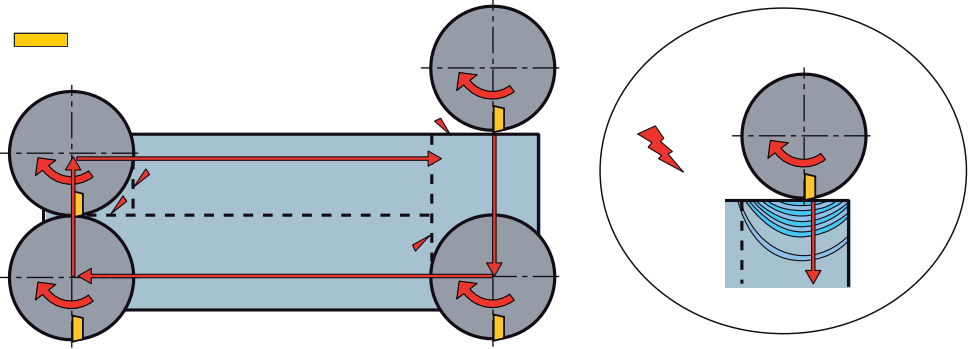

Rolling around all corners should always be applied as a key step to providing a robust optimised process.

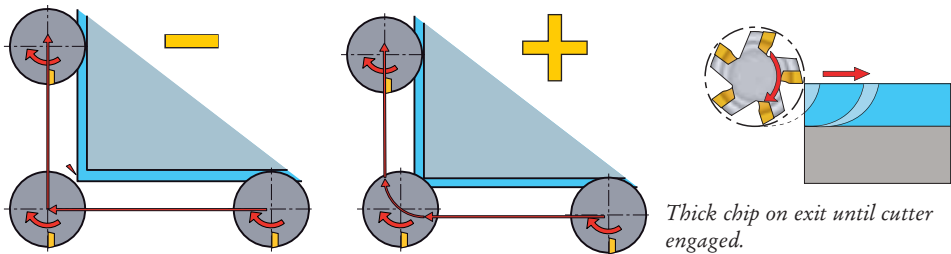
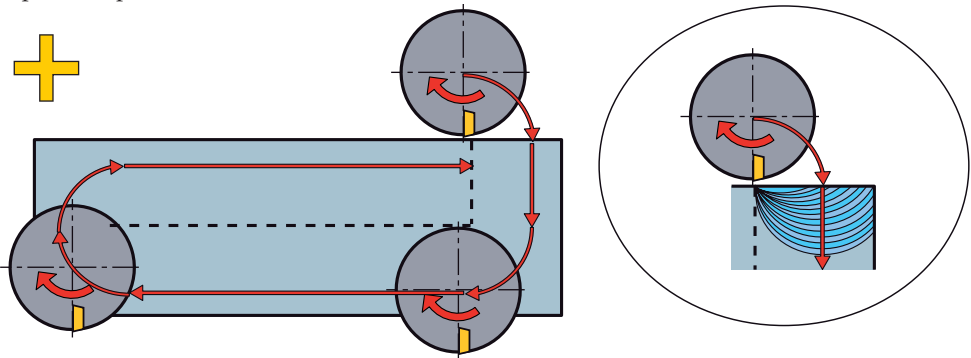

To ensure that the corner is covered the maximum (and optimum) width of cut should be a_c 70% of D_c .

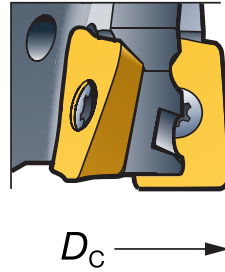

Programmed radius = 50% D_c

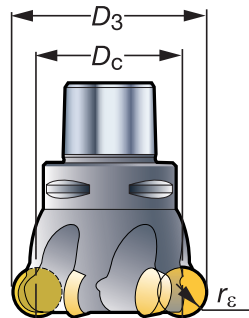
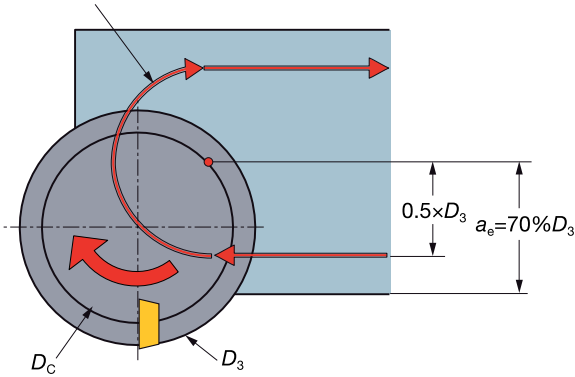

- Keep cutter constantly engaged.
- Program around interruptions and holes.

