

EasyFix

Sleeves for cylindrical bars

For correct mounting of cylindrical bars

EasyFix gives a fast and simple way of achieving correct indexing of centre height when mounting cylindrical bars into the machine, due to a spring loaded plunger design.

The slot in the cylindrical sleeve is filled with a silicon sealer which allows the existing coolant supply system to be used.

The EasyFix sleeves fit a wide range of products; CoroTurn® 107, Silent tools damped boring bars and also our CoroCut® MB system.

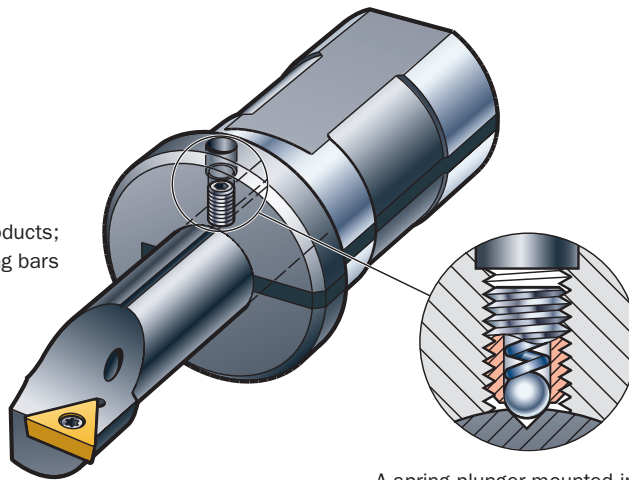

A spring plunger mounted in the sleeve clicks into a groove in the bar to guarantee correct centre height and fast and simple handling when mounting the cylindrical bar into the machine.

Correct clamping with EasyFix

Conventional lathe

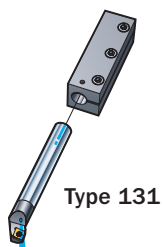

Coromant Capto®

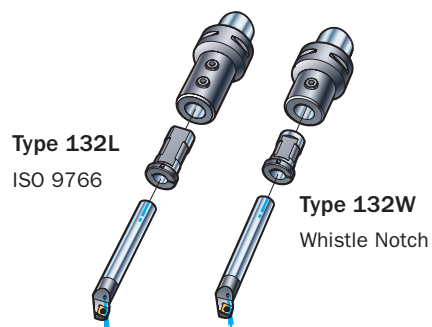

Turret type lathe

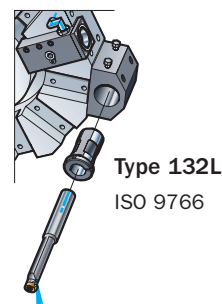

Sliding head machine

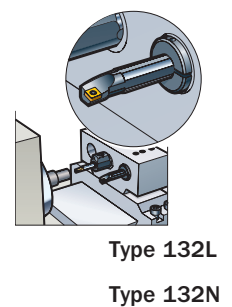

EasyFix sleeves for cylindrical bars

Square sleeves

Bar diameter, mm	Ordering code	Dimensions, mm				Spare parts	
		h_z	h	b	h_x	Screw	Key
131-	dm_t						
5	131 -2005-B	80	20	20	5.5	3212 010-258	174.1-864
6	131 -2006-B	80	20	20	6	3212 010-258	174.1-864
8	131 -2008-B	80	20	20	7	3212 010-258	174.1-864
10	131 -2010-B	80	20	20	7.5	3212 010-258	174.1-864
12	131 -2512-B	80	25	25	9	3212 010-259	174.1-864

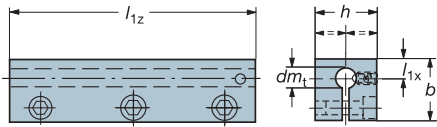

Sleeves for boring bars, type 131- and 132-, can be used for all Sandvik Coromant boring bars in diameter range 5-12 mm

Cylindrical sleeves

Bar diameter, mm	Ordering code	Dimensions, mm		
		h_1	h_2	dm_m
132L-	dm_t			
5	132L -1205050-B	5	50	19.05
5	132L -2005050-B	5	50	20
5	132L -2205050-B	5	50	22
5	132L -1605050-B	5	50	25.4
6	132L -1206050-B	5	50	19.05
6	132L -2006050-B	5	50	20
6	132L -2206050-B	5	50	22
6	132L -1606050-B	5	50	25.4
8	132L -1208050-B	5	50	19.05
8	132L -2008050-B	5	50	20
8	132L -2208050-B	5	50	22
8	132L -1608050-B	5	50	25.4
10	132L -1210050-B	5	50	19.05
10	132L -2010050-B	5	50	20
10	132L -2210050-B	5	50	22
10	132L -1610050-B	5	50	25.4
12	132L -1212050-B	5	50	19.05
12	132L -2012050-B	5	50	20
12	132L -2212050-B	5	50	22
12	132L -1612050-B	5	50	25.4
6	132L -2506-B	5	61	25
8	132L -2508-B	5	61	25
10	132L -2510-B	5	61	25
12	132L -2512-B	5	61	25
5	132L -2505085-B	5	85	25
5	132L -3205085-B	5	85	32
6	132L -3206085-B	5	85	32
8	132L -3208085-B	5	85	32
10	132L -3210085-B	5	85	32
12	132L -3212085-B	5	85	32
6	132L -4006105-B	5	105	40
8	132L -4008105-B	5	105	40
10	132L -4010105-B	5	105	40
12	132L -4012105-B	5	105	40
12	132L -5012125-B	5	125	50

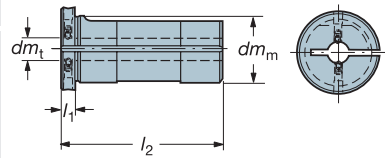

Sleeves for boring bars, type 131- and 132-, can be used for all cylindrical Sandvik Coromant boring bars in diameter range 5-12 mm

EasyFix sleeves for cylindrical bars

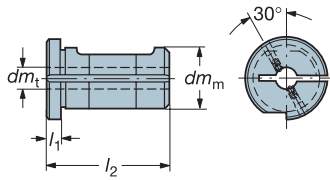
Cylindrical sleeves	Clamping diameter	Ordering code	Dimensions, mm		
			l_1	l_2	dm_m
132W- (Whistle Notch)	dm_t				
	5	132W-2505-B	5	50	25
	6	132W-2506-B	5	50	25
	8	132W-2508-B	5	50	25
	10	132W-2510-B	5	50	25
	12	132W-2512-B	5	50	25

For bars with flats

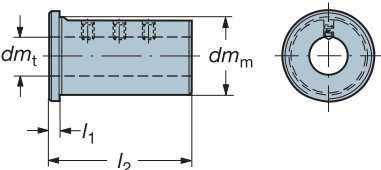
132N-	Clamping diameter	Ordering code	Dimensions, mm			Spare parts	
			l_1	l_2	dm_m	Screw	Key
	dm_t						
	6	132N-2506	5	61	25	3214 010-356	174.1-864 (3.0)
	8	132N-2508	5	61	25	3214 010-406	174-815 (4.0)
	10	132N-2510	5	61	25	3214 010-405	174-815 (4.0)
	12	132N-2512	5	61	25	3214 010-405	174-815 (4.0)

Sleeves for boring bars, type 131- and 132-, can be used for all cylindrical Sandvik Coromant boring bars in diameter range 5-12 mm

Coolant connectors

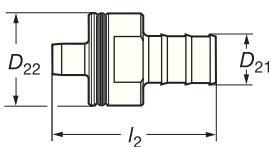
	Bar dia.	Ordering code	Dimensions, mm		
			D_{21}	D_{22}	l_2
	dm_m				
	6	CS-060-054	5.4	6.0	25.0
	8	CS-080-066	6.6	8.0	28.5
	10	CS-100-086	8.6	10.0	28.5
	12	CS-120-086	8.6	12.0	38.0